

## DA50A FlexEdge™ 1-Sled Gateway Installation Guide

- Modular architecture allows for upgrading of software and hardware capabilities
- Advanced networking capabilities including routing, NAT, and firewall features
- Enhanced automation, IIoT and Crimson Control capabilities are model specific
- Fully isolated design provides reliable operation
- Independent serial ports provide virtually unlimited integration methods
- 10 Base-T/100 Base-TX Ethernet connection provides networking capability
- Configured using web GUI or Crimson® software (version 3.2 or later)



II 3 G Ex ec IIC T4 Gc  
DEMKO 20 ATEX 2268X  
IECEx UL 20.0007X



FOR USE IN HAZARDOUS LOCATIONS:  
Class I, Division 2, Groups A, B, C, and D  
T4

### GENERAL DESCRIPTION

The DA50A provides networking and automation capabilities in a modular architecture to ensure easy deployment in any industrial application. This modular design makes ensuring compatibility with rapidly evolving communications standards as easy as replacing a field-installable sled. Easily upgrade the gateway to a more advanced feature set to meet changing application requirements. With an intuitive LED status ring, diagnosing issues is simple and straightforward. The DA50A delivers a compact adaptable solution that securely connects industrial applications.

### GATEWAY PACKAGE CHECKLIST

This product package should contain the items listed below. This list does not include any sleds that may have been ordered. If any items are missing or damaged, contact Red Lion immediately.

- DIN Rail Mount DA50A Gateway
- Pre-installed Sled Holder
- Installation Guide

### SAFETY SUMMARY

All safety related regulations, local codes as well as instructions that appear in this document or on equipment must be observed to ensure personal safety and to prevent damage to either the device or equipment connected to it.

Do not use these products to replace proper safety interlocking. No software-based device (or any other solid-state device) should ever be designed to be responsible for the maintenance of personnel safety or consequential equipment not equipped with safeguards. Red Lion disclaims any responsibility for damages, either direct or consequential, that result from the use of this equipment in a manner not consistent with these specifications.



**CAUTION: Risk of Danger**  
Read complete instructions prior to installation and operation of the unit.  
**ATTENTION : Risque de danger**  
Lire les instructions complètes avant l'installation et l'utilisation de l'appareil.



**WARNING - EXPLOSION HAZARD - SUBSTITUTION OF COMPONENTS MAY IMPAIR SUITABILITY FOR CLASS I, DIVISION 2**  
**AVERTISSEMENT - DANGER D'EXPLOSION - LE REMPLACEMENT DE COMPOSANTS PEUT NUIRE L'APTITUDE À LA CLASSE I, DIVISION 2**



This equipment is suitable for use in Class I, Division 2, Groups A, B, C, D, or non-hazardous locations only.  
Cet équipement est adapté à une utilisation dans des endroits de classe I, Division 2, Groupes A, B, C, D, ou dans des endroits non dangereux seulement.



**WARNING - EXPLOSION HAZARD. NOT HOT SWAPPABLE. DO NOT REMOVE OR REPLACE WHILE CIRCUIT IS LIVE UNLESS THE AREA IS FREE OF IGNITIBLE CONCENTRATIONS.**  
**AVERTISSEMENT - RISQUE D'EXPLOSION. PAS ÉCHANGEABLE À CHAUD. NE PAS RETIRER OU REMPLACER TANT QUE LE CIRCUIT EST SOUS TENSION SAUF SI LA ZONE EST EXEMPTÉ DE TOUTE CONCENTRATION INFLAMMABLE.**

**SPECIFICATIONS**

**1. POWER REQUIREMENTS:**

The DA50A Gateway must use a Class 2 circuit according to National Electrical Code (NEC), NFPA-70 or Canadian Electrical Code (CEC), Part I, C22.1 or a Limited Power Supply (LPS) according to IEC 60950-1 or Limited-energy circuit according to IEC 61010-1.

Power connection via removable five position terminal block.  
Supply Voltage: 12 to 24 VDC +/- 15%, Class 2 source

INPUT VOLTAGE	12 V	24 V
Typ. Power DA50A Gateway only	2.5 W	2.6 W
Max Power DA50A Gateway only	3.0 W	3.1 W
Max Power DA50A Gateway, with Sleds	5.6 W	5.7 W

**2. BATTERY:** 3 V Lithium coin cell. Typical lifetime of 5 years, at nominal usage. To maintain UL rating, replacement battery must be: Red Lion CRA000 BT3V0 00000, Rayovac BR1225X-BA or Panasonic BR1225A/BN.

**3. MEMORY:**

On Board User Memory: 1 GB of non-volatile Flash memory.  
Memory Card: microSD slot accepts Class 5 or better microSD cards up to 256 GB capacity. FAT32, industrial grade.

**4. COMMUNICATION CAPABILITIES:**

USB Device Port: Isolated USB 2.0 full speed, type B connection. USB DEVICE PORT IS FOR SYSTEM SET-UP AND DIAGNOSTICS AND IS NOT INTENDED FOR PERMANENT CONNECTION.

Ethernet Ports: Two 10BaseT/100BaseTX RJ-45 Ports, auto MDI/MDI-X.

Isolation from Ethernet network to gateway: 1500 Vrms  
Serial Ports: Two serial ports with individual port isolation; 1 - RS-232 port (RJ12 connector) and 1 - RS-485/422 port (RJ45 connector)

**5. DIGITAL OUTPUT (DOUT):**

Configuration: Open Collector, reference to ground  
Absolute Maximum IDC: 500 mADC (Vce = 750 mVDC)  
Absolute Maximum VDC: 30 VDC (open circuit)  
Absolute Minimum VDC: -0.4 VDC (open circuit)

**6. DIGITAL INPUT (DIN):**

Configuration: Unisolated level detection, reference to ground  
Active level: 2.5 VDC to 30 VDC  
Inactive level: 0 VDC to 1.3 VDC  
Absolute Minimum VDC: -0.3 VDC  
Absolute Maximum VDC: 33 VDC  
Leakage IDC at 5 VDC: 150 uADC

**7. ANALOG INPUT (Shared with Digital Input) (DIN/AI1):**

Configuration: Unisolated input, reference to ground  
Resolution: 4096 (ADC 12-bit)  
VDC per step: 9.483 mVDC (full scale level: 38.8 V)  
Accuracy: 2%  
Zero level: 0 VDC  
Absolute Minimum VDC: -0.3 VDC  
Absolute Maximum VDC: 33 VDC  
Leakage IDC at 5 VDC: 265.96 uADC typical

**8. ENVIRONMENTAL CONDITIONS:**

Operating Temperature Range: -40 to 75 °C  
Storage Temperature Range: -40 to 85 °C  
Operating and Storage Humidity: 0 to 85% max. RH non-condensing  
Vibration to IEC 60068-2-6: Operational 5-500 Hz, 2 g  
Shock to IEC 60068-2-27: Operational 15 g  
Altitude: Up to 2000 meters  
Installation Category II, Pollution Degree 2 as defined in IEC/EN 60664-1.

**9. CERTIFICATIONS AND COMPLIANCES:**

CE Approved  
EN 61326-1 Immunity to Industrial Locations  
Emission CISPR 11 Class A  
IEC/EN 61010-1  
RoHS Compliant  
ATEX Approved  
II 3 G Ex ec IIC T4 Gc  
DEMKO 20 ATEX 2268X  
IECEX Approved  
IECEX UL 20.0007X  
UL Hazardous: File # E317425  
Rugged IP30 enclosure

**10. CONNECTIONS:**

Power Connection: Five-pin top mounted connector  
Wire Strip Length: 0.3" (7.5 mm)  
Wire Gauge Capacity: 12 to 24 AWG (3.31 to 0.20 mm<sup>2</sup>)  
copper wire only  
Torque: 4.4-5.3 inch-lbs (0.5-0.6 N-m)

**11. CONSTRUCTION:** Polycarbonate enclosure with IP30 rating.

For use only in an approved enclosure.

**12. MOUNTING REQUIREMENTS:** Mounts onto standard DIN style top hat (T) profile mounting rails according to EN50022 - 35 x 7.5 mm and 35 x 15 mm.

**13. WEIGHT:** 13 oz (404.3 g)

**DIMENSIONS In Inches (mm)**

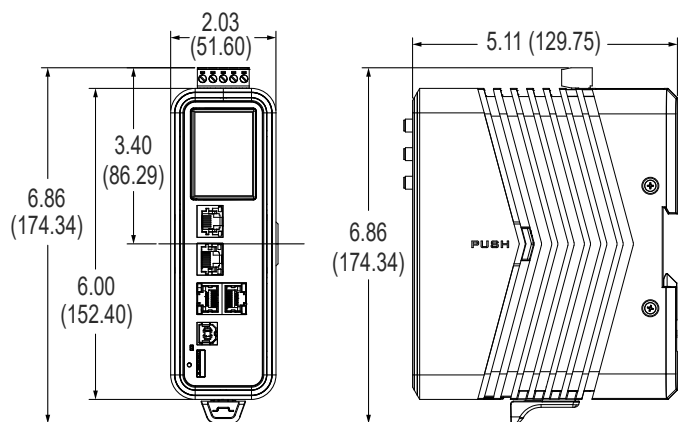

## EMC INSTALLATION GUIDELINES

Although Red Lion Controls products are designed with a high degree of immunity to Electromagnetic Interference (EMI), proper installation and wiring methods must be followed to ensure compatibility in each application. The type of the electrical noise, source or coupling method into a unit may be different for various installations. Cable length, routing, and shield termination are very important and can mean the difference between a successful or troublesome installation. Listed are some EMI guidelines for a successful installation in an industrial environment.

1. A unit should be mounted in a metal enclosure, which is properly connected to protective earth.
2. Use shielded cables for all Signal and Control inputs. The shield connection should be made as short as possible. The connection point for the shield depends somewhat upon the application. Listed below are the recommended methods of connecting the shield, in order of their effectiveness.
  - a. Connect the shield to earth ground (protective earth) at one end where the unit is mounted.
  - b. Connect the shield to earth ground at both ends of the cable, usually when the noise source frequency is over 1 MHz.
3. Never run Signal or Control cables in the same conduit or raceway with AC power lines, conductors, feeding motors, solenoids, SCR controls, and heaters, etc. The cables should be run through metal conduit that is properly grounded. This is especially useful in applications where cable runs are long and portable two-way radios are used in close proximity or if the installation is near a commercial radio transmitter. Also, Signal or Control cables within an enclosure should be routed as far away as possible from contactors, control relays, transformers, and other noisy components.
4. Long cable runs are more susceptible to EMI pickup than short cable runs.
5. In extremely high EMI environments, the use of external EMI suppression devices such as Ferrite Suppression Cores for signal and control cables is effective. The following EMI suppression devices (or equivalent) are recommended:
  - Fair-Rite part number 0443167251 (Red Lion #FCOR0000) Line Filters for input power cables:
  - Schaffner # FN2010-1/07 (Red Lion #LFIL0000)
6. To protect relay contacts that control inductive loads and to minimize radiated and conducted noise (EMI), some type of contact protection network is normally installed across the load, the contacts or both. The most effective location is across the load.
  - a. Using a snubber, which is a resistor-capacitor (RC) network or metal oxide varistor (MOV) across an AC inductive load is very effective at reducing EMI and increasing relay contact life.
  - b. If a DC inductive load (such as a DC relay coil) is controlled by a transistor switch, care must be taken not to exceed the breakdown voltage of the transistor when the load is switched. One of the most effective ways is to place a diode across the inductive load. Most Red Lion products with solid state outputs have internal zener diode protection. However external diode protection at the load is always a good design practice to limit EMI. Although the use of a snubber or varistor could be used.

Red Lion part numbers: Snubber: SNUB0000  
Varistor: ILS11500 or ILS23000
7. Care should be taken when connecting input and output devices to the instrument. When a separate input and output common is provided, they should not be mixed. Therefore a sensor common should NOT be connected to an output common. This would cause EMI on the sensitive input common, which could affect the instrument's operation.

Visit <https://www.redlion.net/emi> for more information on EMI guidelines, Safety and CE issues as they relate to Red Lion products.

## INSTALLATION

### Gateway DIN Rail Mounting

The DIN rail should be mounted horizontally so that the unit's ventilation holes are vertical in relation to installation orientation. A minimum clearance of 1 inch (25.4 mm) should be maintained above and below the unit in order to ensure proper thermal regulation. For environments with vibration or impacts, DIN rail clamps are recommended.

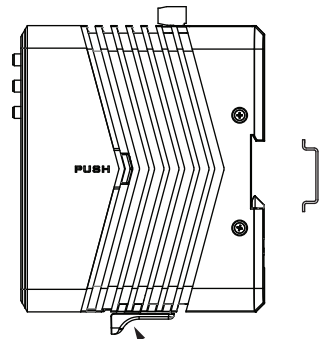

For hazardous location installation, the following shall be taken into consideration:

- The equipment shall only be used in an area of at least pollution degree 2, as defined in EN/IEC 60664-1.
- The equipment shall be installed in an enclosure that provides a minimum ingress protection of IP54 in accordance with EN/IEC 60079-0. The enclosure shall be accessible only with the use of a tool.
- Transient protection shall be provided that is set at a level not exceeding 140% of the peak rated voltage value at the supply terminals to the equipment.

### Recommended DIN Rail Mounting Steps:

1. Ensure the DIN rail lock latch is in the outward most position (unlocked). Hook the top back of the DA50A DIN rail clip on the unit over the DIN rail.
2. Push the bottom of the unit towards the DIN rail until the unit is flush with the rail.
3. Push the DIN rail lock latch to the latched (in) position.

### Recommended DIN Rail Removal Steps:

1. Move the DIN rail lock latch to the unlatched (out) position.
2. Unhook the top of the unit and remove it from the DIN rail.

## SLED INSTALLATION

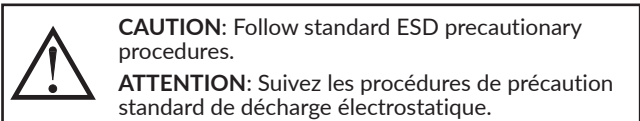

1. Prior to installing the Sled for your DA50A Gateway application, ensure that the Gateway is not receiving power.
2. Disconnect and remove your DA50A from the DIN rail.
3. Remove the DA50A Gateway's front cap by squeezing the sides and pulling.
4. Slide out the sled holder.
5. Install a sled into the sled holder and hand tighten the captive fasteners, or use a screwdriver.
6. Re-install the sled holder containing the sled into the Gateway. Make sure it is fully seated.
7. Replace the front cap.

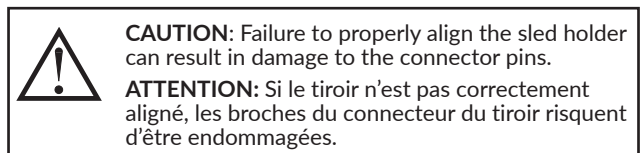

## POWER SUPPLY REQUIREMENTS

The DA50A Gateway requires a 12-24 VDC power supply. Your unit may draw considerably less than the maximum rated power depending upon the configuration and features being used. Your unit will draw increased power with a sled installed. Items that could cause increases in current are microSD card, communications sleds, and other features programmed through software.

To ensure you do not exceed the capacity of your DA50A Gateway host power supply, calculate the total power consumption required for all planned accessories.

It is very important that the power supply meets the following requirements and is mounted correctly if the unit is to operate reliably. Please take care to observe the following points:

- The power supply must be mounted close to the unit, with usually not more than 6 feet (1.8 m) of cable between the supply and the Gateway. Ideally, the shortest length possible should be used.
- The wire used to connect the Gateway power supply should be at least 22-gauge wire. If a longer cable run is used, a heavier gauge wire should be used. The routing of the cable should be kept away from large capacitors, inverters, and other devices which may generate significant electrical noise.
- Use a power supply with an NEC Class 2 or Limited Power Source (LPS) and SELV (safety extra-low voltage) rating. This type of power supply provides isolation to accessible circuits from hazardous voltage levels generated by a mains power supply due to single faults. Safety extra-low voltage circuits shall exhibit voltages safe to touch both under normal operating conditions and after a single fault, such as a breakdown of a layer of basic insulation or after the failure of a single component has occurred.
- Peak efficiency (DA50A) occurs at the low side of the voltage range (approx. 12 V), recommended for high temperature applications.

Visit [www.redlion.net](http://www.redlion.net) for a complete list of our NEC Class 2 power supplies.

## WIRING

All power, input and output (I/O) wiring must be in accordance with Class 1, Division 2 wiring methods and in accordance with the authority having jurisdiction.



**CAUTION:** Only UL listed wiring with temperature ratings greater than 90 °C permitted for Class 1, Division 2, Zone 2 and ATEX/IECex installations.

**ATTENTION:** Seul le câblage homologué UL avec des températures nominales supérieures à 90°C est autorisé pour les installations de classe 1, Division 2, zone 2 et ATEX/IECex.

## CONNECTING TO EARTH GROUND

Each DA50A has a chassis ground terminal on the top of the unit. Your unit should be connected to earth ground. Steps should be taken beyond connecting to earth ground to eliminate the buildup of electrostatic charges.

The chassis ground is not connected to signal common of the unit. Maintaining isolation between earth ground and signal common is not required to operate your unit. But, other equipment connected to this unit may require isolation between signal common and earth ground. To maintain isolation between signal common and earth ground care must be taken when connections are made to the unit. For example, a power supply with isolation between its signal common and earth ground must be used. Also, plugging in a USB cable may connect signal common and earth ground.<sup>1</sup>

<sup>1</sup> USB's shield may be connected to earth ground at the host. USB's shield in turn may also be connected to signal common.

## DA50A PORT PINOUTS

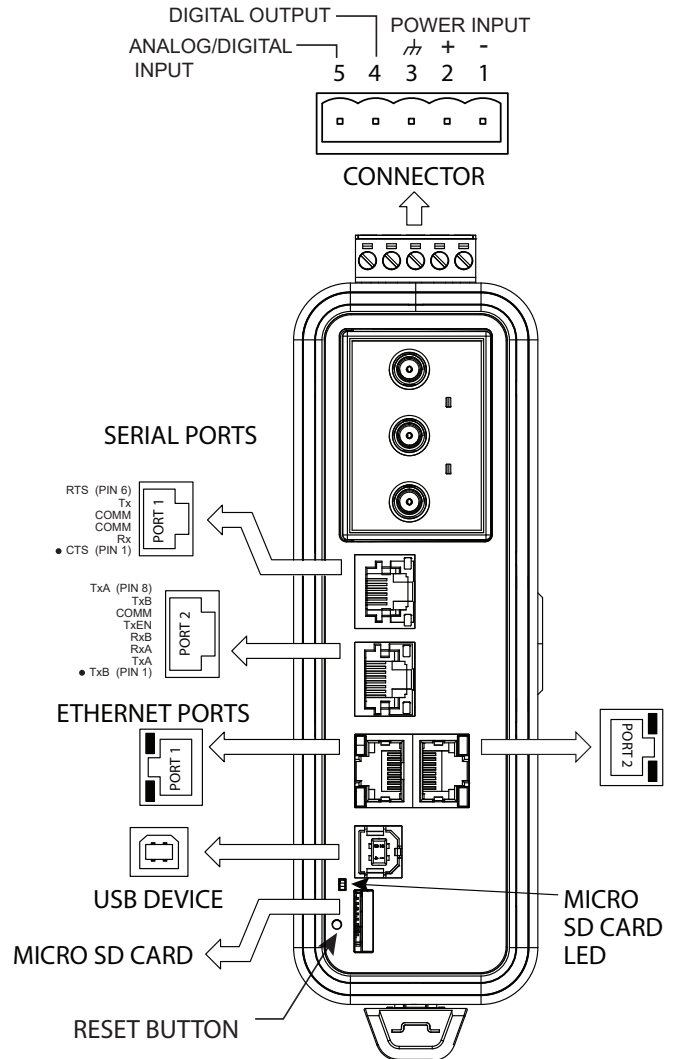

## FACTORY RESET BUTTON

The factory reset button located in the lower left area of the front of the unit can be used to clear the configuration. Hold in the reset button at power up until the status ring LED turns bright white. Click the button to cycle through colors on the status ring LED. If left at white, the unit will boot its existing configuration, and if left at red it will clear the units memory. Once the memory is cleared, the user will need to use the default password printed on the unit to access the configuration.

## CONFIGURING A DA50A

The DA50A can be configured using Crimson® 3.2 software. Crimson is available as a no charge download from Red Lion's website. Crimson updates for new features and drivers are posted on the website as they become available. By configuring the DA50A using the latest Crimson version, you are assured that your unit has the most up to date feature set. Crimson software can configure the DA50A through the Serial programming port, USB device port, Ethernet ports or microSD card.

The microSD card can be used to program a DA50A by placing an image file on the microSD card. The card is then inserted into the target DA50A and powered. Refer to the Crimson 3.2 User Manual for more information on the proper names and locations of this file.

### DA50A Web User Interface

1. Connect a PC to the DA50A Gateway using an Ethernet cable to Ethernet port 2 on the Gateway.
2. Set up the PC IP address by filling in the blank fields with the information below:

Ethernet	Port
IP Address	192.168.222.2
Subnet Mask	255.255.255.0
Default Gateway	192.168.222.1
Preferred DNS	192.168.222.1

3. Open a web browser and enter the following in the address bar: <https://192.168.222.222>
4. To log in to the System webserver for the first time:
  - User Name: admin
  - Password: Refer to unique password located on unit
  - Note: For security, it is recommended to change the password according to your company's internal policy. To change the password, go to Administrator → Change Password.

### DA50A Cellular Connectivity

Cellular connectivity is achieved using the DA 4G LTE - CAT4/ CAT1 Modem Sled. Refer to the documentation shipped with your DA 4G LTE - CAT4/CAT1 Modem Sled for installation and setup information.

**WARNING** - Do not connect or disconnect cables while power is applied unless area is known to be non-hazardous. Not hot swappable.

### Ethernet Communications

Ethernet communications can be established at either 10 BASE-T or 100 BASE-TX. The DA50A's RJ45 jack is wired as a NIC (Network Interface Card). For example, when wiring to a hub or switch use a straight-through cable, but when connecting to another NIC use a crossover cable. Refer to the Crimson 3.2 Software Guide and Red Lion's website for additional information on Ethernet communications.

LED COLOR(S)	MEANING
YELLOW solid	Link established.
YELLOW flashing	Data being transferred.
GREEN (OFF)	10 BASE-T Communications
GREEN (ON)	100 BASE-TX Communications

### RS232 PORT

The DA50A has one RS232 serial port that can be used for either programming or for communications. The RS232 port can be used for either master or slave protocols. The serial port has a pair of LEDs to indicate transmit and receive activity. The pinout is shown to the right.

DA50A RS232 TO A PC			
DA50A: RJ12		PC: DB9	
Pin #	Name	Pin #	Name
4	COMM	1	DCD
5	Tx	2	Rx
2	Rx	3	Tx
	N/C	4	DTR
3	COMM	5	GND
	N/C	6	DSR
1	CTS	7	RTS
6	RTS	8	CTS
	N/C	9	RI

### RS485/422 COMMS PORT

The RS485 port of the DA50A can be used for RS485 or RS422 communication. The serial port has a pair of LEDs to indicate transmit and receive activity.

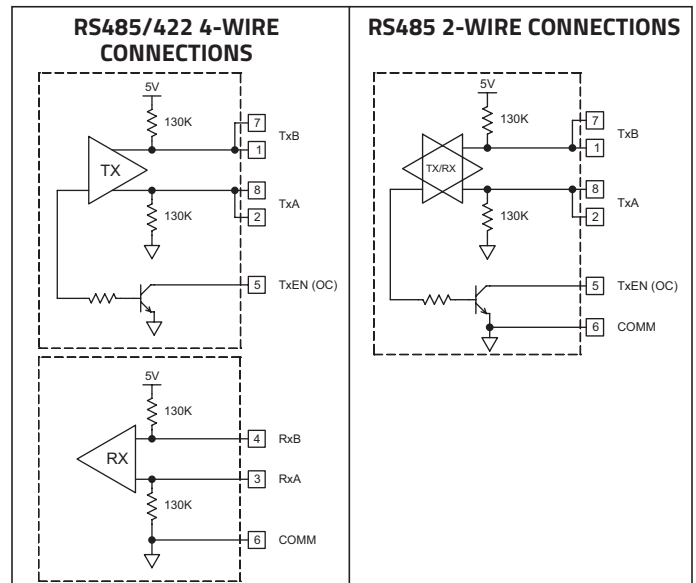

Note: All Red Lion devices connect A to A and B to B. Refer to [www.redlion.net](http://www.redlion.net) for additional information.

### Examples of RS485 2-Wire Connections

DA50A TO RED LION RJ11			
DA50A : RJ45		RLC : RJ11	
Pin #	Name	Pin #	Name
5	TxEN	2	TxEN
6	COMM	3	COMM
1	TxB	5	B-
2	TxA	4	A+

DA50A TO MODULAR CONTROLLER			
DA50A		Modular Controller	
Pin #	Name	Pin #	Name
1,4	TxB	1,4	TxB
4,1	RxB	4,1	RxB
2,3	TxA	2,3	TxA
3,2	RxA	3,2	RxA
5	TxEN	5	TxEN
6	COMM	6	COMM
7	TxB	7	TxB
8	TxA	8	TxA

### DH485 COMMUNICATIONS

The DA50A's RS485/422 COMMS port can also be used for Allen Bradley DH485 communications.

**WARNING: DO NOT** use a standard DH485 cable to connect this port to Allen Bradley equipment. A cable and wiring diagram are available from Red Lion at [www.redlion.net/cables-drivers](http://www.redlion.net/cables-drivers).

### STATUS RING LED

LED COLOR/STATE	MEANING
Pulsating white	PXE starting up
Steady dim white	PXE running with Crimson stopped
Steady pale green	PXE running with Crimson running
Steady pale red	Accepted alarms present
Pulsating red	Active Alarms present
Pulsating red and green	Identify command received
Flashing red and white	C3.2 crashed and restarting

### INSTALL THE microSD CARD

Insert the microSD card into the slot on the front of the Gateway with the card oriented as shown. The card is inserted properly when the card clicks into place in the card holder. To remove the microSD card, push in slightly on the card.

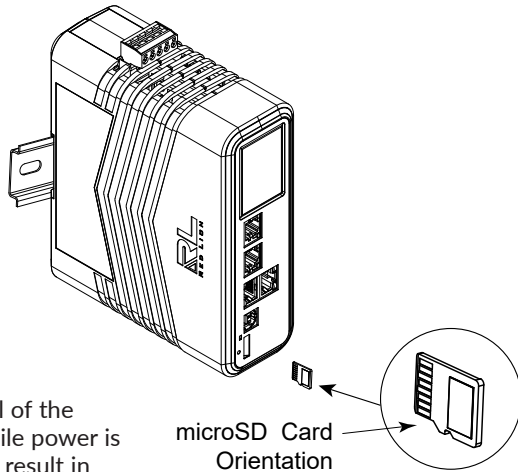

Note: Removal of the microSD while power is applied may result in corruption or loss of data.

microSD Card Orientation



**CAUTION:** Lithium battery. Danger of explosion if battery is incorrectly replaced. Replace only with the same or equivalent type recommended by the manufacturer.

**ATTENTION:** Pile au lithium. Danger d'explosion si la batterie est mal remplacée. Remplacez-la uniquement par une pile du même type ou d'un type équivalent recommandé par le fabricant.



Please note that the old battery must be disposed of in a manner that complies with your local waste regulations. The battery must not be disposed of in fire, or in a manner whereby it may be damaged and its contents could come into contact with human skin.

Veillez noter que la vieille pile doit être éliminée conformément à la réglementation locale en matière de déchets. La pile ne doit pas être jetée au feu, ni d'une manière qui pourrait l'endommager et son contenu pourrait entrer en contact avec la peau humaine.

### DA50A GATEWAY BATTERY & TIME KEEPING

**WARNING - Explosion Hazard -** The area must be known to be non-hazardous before servicing/ replacing the unit and before installing or removing I/O wiring and battery. Not hot swappable.

A battery is used to keep time when the unit is without power. The battery of a DA50A Gateway unit does not affect the unit's memory, all configurations and data is stored in non-volatile memory.

### Changing the Battery

To change the battery of a DA50A Gateway, first remove power to the unit. Insert a small screwdriver into the slot provided on the battery holder and pry the battery holder out of the unit. Remove the old battery from the holder and replace it with a new battery.

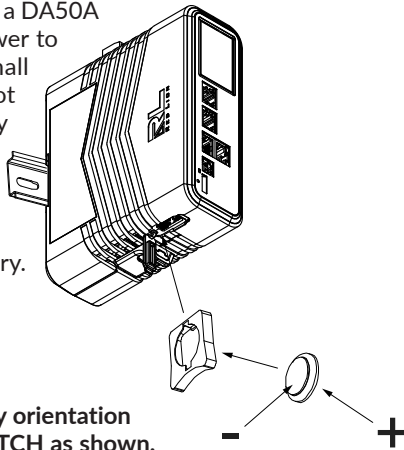

Note: Battery orientation MUST MATCH as shown.

To maintain UL rating, battery must be replaced with one listed in the Specifications.

### RED LION CONTROLS TECHNICAL SUPPORT

If for any reason you have trouble operating, connecting, or simply have questions concerning your new DA50A Gateway, contact Red Lion's technical support.

Support: [support.redlion.net](http://support.redlion.net)

Website: [www.redlion.net](http://www.redlion.net)

Inside US: +1 (877) 432-9908

Outside US: +1 (717) 767-6511

Red Lion Controls, Inc.

20 Willow Springs Circle York, PA 17406

**ORDERING INFORMATION**

SOFTWARE GROUPS				
	Group 1 Networking	Group 2 Protocol	Group 3 IIoT	Group 4 Controller
<b>Configuration</b>				
Web GUI	Y	Y	Y	Y
Crimson	Y	Y	Y	Y
<b>Networking</b>				
Firewall	Y	Y	Y	Y
RADIUS Auth.	Y	Y	Y	Y
Routing	Y	Y	Y	Y
NAT	Y	Y	Y	Y
IP Fallback	Y	Y	Y	Y
VPN Client/Server	Y	Y	Y	Y
<b>Automation</b>				
300+ Drivers		Y	Y	Y
IIoT Connectors		Y	Y	Y
OPC UA		Y	Y	Y
SQL Sync			Y	Y
Data Logging			Y	Y
Virtual HMI			Y	Y
Advanced Web Server			Y	Y
<b>IEC Control</b>				
Crimson Control				Y

**Main Unit**

PART NUMBER	SW GROUP	DESCRIPTION
DA50A 0BNN00 00010	Group 1	FlexEdge 1-Sled Mixed Serial Networking Gateway
DA50A 0BNN00 00020	Group 2	FlexEdge 1-Sled Mixed Serial Protocol Gateway
DA50A 0BNN00 00030	Group 3	FlexEdge 1-Sled Mixed Serial Adv IIoT Gateway
DA50A 0BNN00 00040	Group 4	FlexEdge 1-Sled Mixed Serial Adv Automation Controller

**Accessories**

PART NUMBER	DESCRIPTION
DAS00 CL9C4S AM000	4G LTE (CAT4) Cellular Sled for AMER (AT&T, Generic)
DAS00 CL9C1S AZ000	4G LTE (CAT1) Cellular Sled for AUS (Telstra)
DAS00 CL9C4S VZ000	4G LTE (CAT4) Cellular Sled for AMER (Verizon)
DAS00 CL9C4S EU000	4G LTE (CAT4) Cellular Sled for EMEA, SAARC, APAC
DAS00 WF10NO AM000	802.11n Wi-Fi Sled
DAS00 PN40U4 00000	1 Port USB 2.0 Host Sled
DAS00 PN2221 IS000	Dual RS232 Ports Sled (Isolated)
DAS00 PN2442 IS000	Dual RS485 Ports Sled (Isolated)
DAS00 PN2245 IS000	Mixed RS232/RS485 Ports Sled (Isolated)

Spaces in listed part numbers are shown to improve readability,  
do not include when searching for or ordering these parts.

## **COPYRIGHT**

©2020 Red Lion Controls, Inc. All rights reserved. Red Lion and the Red Lion logo are trademarks of Red Lion Controls, Inc. All other company and product names are trademarks of their respective owners.

### **LIMITED WARRANTY**

(a) Red Lion Controls Inc. (the "Company") warrants that all Products shall be free from defects in material and workmanship under normal use for the period of time provided in "Statement of Warranty Periods" (available at [www.redlion.net](http://www.redlion.net)) current at the time of shipment of the Products (the "Warranty Period"). **EXCEPT FOR THE ABOVE-STATED WARRANTY, COMPANY MAKES NO WARRANTY WHATSOEVER WITH RESPECT TO THE PRODUCTS, INCLUDING ANY (A) WARRANTY OF MERCHANTABILITY; (B) WARRANTY OF FITNESS FOR A PARTICULAR PURPOSE; OR (C) WARRANTY AGAINST INFRINGEMENT OF INTELLECTUAL PROPERTY RIGHTS OF A THIRD PARTY; WHETHER EXPRESS OR IMPLIED BY LAW, COURSE OF DEALING, COURSE OF PERFORMANCE, USAGE OF TRADE OR OTHERWISE.** Customer shall be responsible for determining that a Product is suitable for Customer's use and that such use complies with any applicable local, state or federal law.

(b) The Company shall not be liable for a breach of the warranty set forth in paragraph (a) if (i) the defect is a result of Customer's failure to store, install, commission or maintain the Product according to specifications; (ii) Customer alters or repairs such Product without the prior written consent of Company.

(c) Subject to paragraph (b), with respect to any such Product during the Warranty Period, Company shall, in its sole discretion, either (i) repair or replace the Product; or (ii) credit or refund the price of Product provided that, if Company so requests, Customer shall, at Company's expense, return such Product to Company.

(d) **THE REMEDIES SET FORTH IN PARAGRAPH (c) SHALL BE THE CUSTOMER'S SOLE AND EXCLUSIVE REMEDY AND COMPANY'S ENTIRE LIABILITY FOR ANY BREACH OF THE LIMITED WARRANTY SET FORTH IN PARAGRAPH (a).**

**BY INSTALLING THIS PRODUCT, YOU AGREE TO THE TERMS OF THIS WARRANTY, AS WELL AS ALL OTHER DISCLAIMERS AND WARRANTIES IN THIS DOCUMENT.**