



**FEATURES**

- 17" TFT SXGA 4:3 LCD with resistive 5-wire / projected capacitive touch
- Intel® 7<sup>th</sup> Gen (Kaby Lake-U) Processor Core™ i5-7300U, Core™ i3-7100U
- 1x 260-pin DDR4 SODIMM. max up to 16GB
- 1x 2.5" SATA HDD bay support RAID 0, 1
- 1x mSATA (shared by 1x Mini PCIe), 1x CFAST (shared by 1x mSATA), 2x SIM socket
- 2x full-size mini PCIe for communication or expansion modules
- 2x LAN, 1x VGA, 1x DisplayPort, 1x Dual Channel 24 bit LVDS
- 4x RS-232/422/485, 4x USB 3.0, Audio
- 8x DI + 8x DO with isolation
- 2x Universal I/O Bracket for Expansion (VIO-217/PC410 Only)
- 9 to 50VDC wide range power input
- -10°C to 60°C extended operating temperature
- Designed with aluminum die-casting front frame
- IP65 compliant front panel
- Two 10W internal speakers built-in
- Multi-language OSD built-in

<b>Display</b>	
LCD Size	17" [4:3]
Max. Resolution	1280 x 1024 (SXGA)
Brightness (cd/m <sup>2</sup> )	350
Contrast Ratio	800:1
LCD Color	16.7M
Pixel Pitch (mm)	0.264 (H) x 0.264 (V)
Viewing Angle (H-V)	170 / 160
Backlight MTBF	50000 hrs (LED Backlight)
<b>Touch</b>	
Resistive 5-wire	VIO-217R/PC400, VIO-217R/PC410
Projected Capacitive	VIO-217C/PC400, VIO-217C/PC410
<b>System</b>	
Processor	7 <sup>th</sup> Gen Intel® Core™ i5-7300U Processor, Dual Core, 3MB Cache, up to 3.5 GHz 7 <sup>th</sup> Gen Intel® Core™ i3-7100U Processor, Dual Core, 3MB Cache, 2.4 GHz
System Chipset	SoC integrated
LAN Chipset	GbE1: Intel® I219LM (Support Wake-on-LAN and PXE) GbE2: Intel® I210-AT (Support Wake-on-LAN and PXE)
Audio Codec	Realtek ALC888S
System Memory	1x 260-Pin DDR4 1866/2133MHz SODIMM. Max. up to 16GB
BIOS	AMI 128Mbit SPI BIOS
Watchdog	Software Programmable Supports 1~255 sec. System Reset
<b>Storage</b>	
SSD/HDD	1x Removable 2.5" SATA HDD Bay Support RAID 0, 1
mSATA	1x mSATA (shared by 1x Mini PCIe)
CFAST	1x CFAST (shared by 1x mSATA)
SIM Socket	2x External SIM socket
<b>Expansion</b>	
Mini PCI Express	2x Full-size Mini PCIe
<b>I/O</b>	
VGA	1x VGA
DisplayPort	1x DisplayPort
LVDS	1x Dual Channel 24 bit LVDS
COM	4x RS-232/422/485 2x RS-232/422/485 (internal) (VIO-217/PC410 only)

USB	4x USB 3.0
LAN	2x RJ45
Audio	1x Mic-in, 1x Line-out
DIO	8 in / 8 out (Isolated)
Universal I/O Bracket	2x Universal I/O Bracket for Expansion (VIO-217/PC410 only)
Others	3x WiFi Antenna Holes (VIO-217-PC400 only) 4x WiFi Antenna Holes (VIO-217-PC410 only) 1x Power Switch, 1x AT/ATX Switch, 1x Remote Power On/Off

**Other Features**

Internal Speaker	AMP 10W + 10W
OSD	LCD On/Off, Auto, Menu, Up and Down Multi-language

**Operating System**

Windows	Windows 10
Linux	Linux kernel 4.X

**Power**

Power Mode	AT, ATX
Power Supply Voltage	9-50VDC
Power Ignition Sensing	Power Ignition Management
Power Connector	3-pin Terminal Block
Power Adaptor	Optional AC/DC 12V/5A, 60W
Power Protection	OVP (Over Voltage Protection) OCP (Over Current Protection) Reverse Protection

**Environment**

Operating Temp.	-10°C to 60°C
Storage Temp.	-20°C to 70°C
Relative Humidity	10%-80% (non-condensing)
IP Level	IP 65 Compliant Front Panel
Vibration	With SSD: 1.5 Grms, 5 - 500 Hz, 0.5 hr/axis With HDD: 1 Grms, 5 - 500 Hz, 0.5 hr/axis
Shock	20G, half sine, 11ms
Standards / Certification	CE, FCC Class A

**Physical**

Front Panel Construction	Die-cast Flat Surface
Dimension	VIO-217/PC400: 407.5 (W) x 339 (D) x 70.5 (H) mm VIO-217/PC410: 407.5 (W) x 339 (D) x 92.5 (H) mm
Weight	TBC
Mounting	VESA Mounting Holes 75 x 75mm, 100 x 100mm

## EXTERNAL I/O MECHANICAL LAYOUT

Front I/O

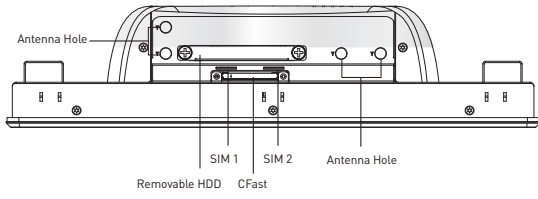

Left I/O

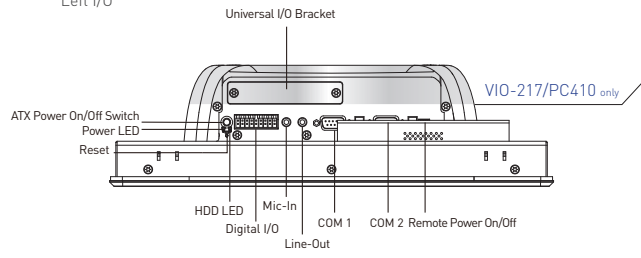

Rear I/O

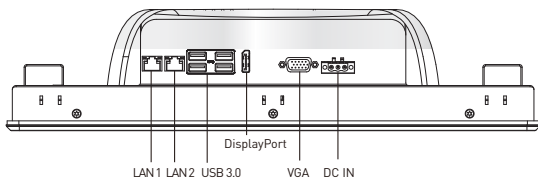

Right I/O

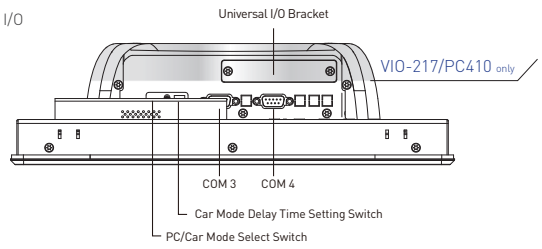

## DIMENSION

Unit: mm

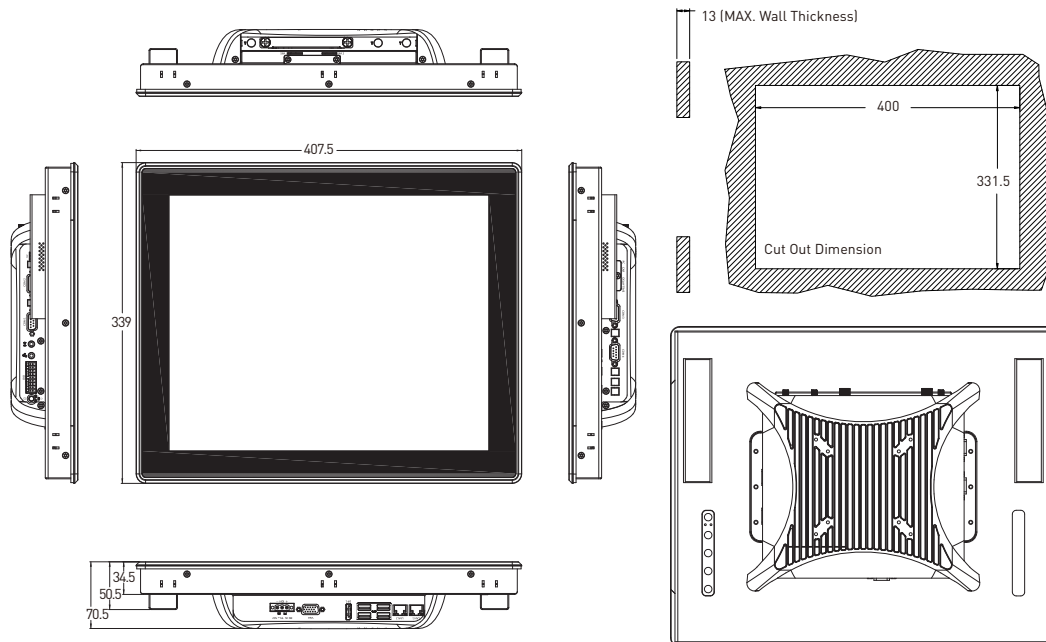

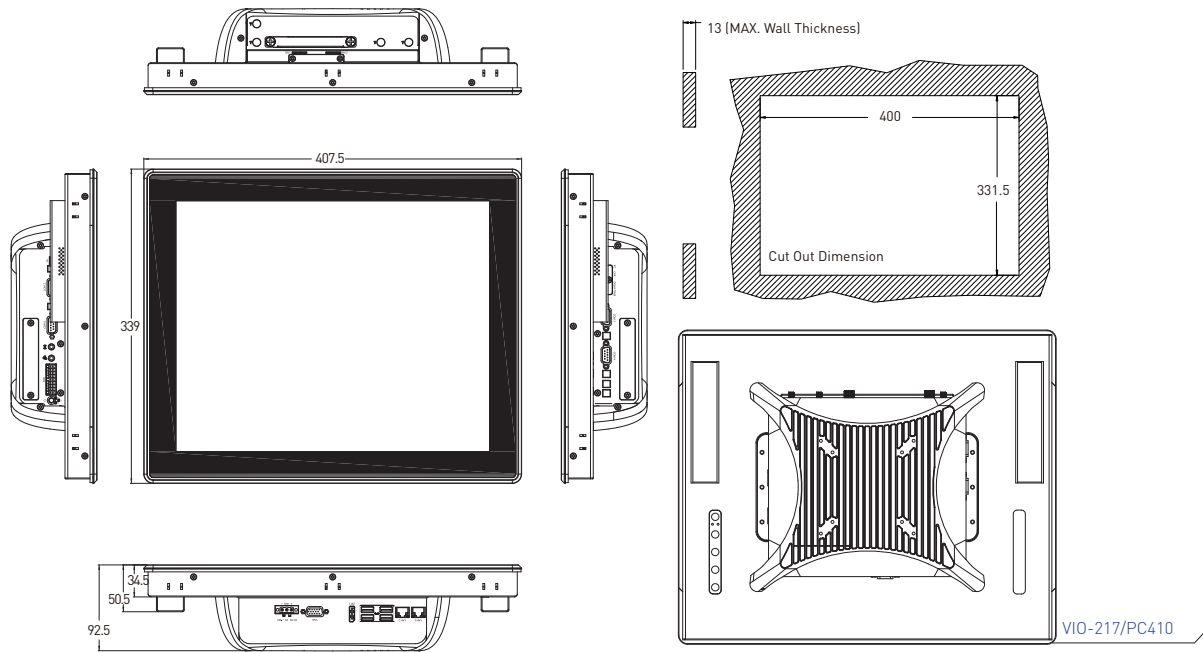

VIO-217/PC410

## ORDERING INFORMATION

MODEL NO.	DESCRIPTION
1-E09A06007	Adapter AC/DC 12V 5A 60W with 3pin Terminal Block Plug 5.0mm Pitch
SFICBL022	Power Cord, 3-pin US Type, 180cm
1-TPCD00002	Power Cord, European Type
1-TPCD00001	Power Cord, 3-pin UK Type, 180cm
3-DINR-0003	DIN-Rail Mount Kit

## PACKING LIST

- 1x VIO-217/PC400 Series Panel PC
- 10x Panel Mount Kit
- 1x Utility DVD Driver
- 1x Screw Pack

## AVAILABLE MODELS

MODEL	MODEL NO.	DESCRIPTION
VIO-217R/PC400	VIO-217R/PC400-7300U	17" SXGA Resistive Touch Thin Frame Panel PC with Intel® Core™ i5-7300U Processor
	VIO-217C/PC400-7300U	17" SXGA Capacitive Touch Thin Frame Panel PC with Intel® Core™ i5-7300U Processor
	VIO-217R/PC400-7100U	17" SXGA Resistive Touch Thin Frame Panel PC with Intel® Core™ i3-7100U Processor
	VIO-217C/PC400-7100U	17" SXGA Capacitive Touch Thin Frame Panel PC with Intel® Core™ i3-7100U Processor
	VIO-217R/PC410-7300U	17" SXGA Resistive Touch Thin Frame Panel PC with Intel® Core™ i5-7300U Processor, 2x Universal I/O Bracket
	VIO-217C/PC410-7300U	17" SXGA Capacitive Touch Thin Frame Panel PC with Intel® Core™ i5-7300U Processor, 2x Universal I/O Bracket
	VIO-217R/PC410-7100U	17" SXGA Resistive Touch Thin Frame Panel PC with Intel® Core™ i3-7100U Processor, 2x Universal I/O Bracket
	VIO-217C/PC410-7100U	17" SXGA Capacitive Touch Thin Frame Panel PC with Intel® Core™ i3-7100U Processor, 2x Universal I/O Bracket