

VIO-217/MX100

17" SXGA Resistive / Capacitive Touch Monitor
with 2x 10W Speaker

FEATURES

- 17" TFT SXGA 4:3 LCD with Resistive 5-wire / Projected Capacitive Touch
- 1x VGA, 1x DVI-D, 1x DisplayPort, 1x USB 2.0, 1x COM, 1x Audio
- 9 to 48VDC wide range power input
- -10°C to 60°C extended operating temperature
- Designed with Aluminum Die-Casting Front Frame
- IP65 Compliant Front Panel
- Two 10W Internal Speakers Built-in
- Multi-language OSD built-in



SPECIFICATIONS

DISPLAY

| | |
|---------------------|---------------------------|
| LCD Size | 17" (4:3) |
| Max. Resolution | 1280 x 1024 (SXGA) |
| Brightness (cd/m2) | 350 |
| Contrast Ratio | 800:1 |
| LCD Color | 16.7M |
| Pixel Pitch (mm) | 0.264 (H) x 0.264 (V) |
| Viewing Angle (H-V) | 170 / 160 |
| Backlight MTBF | 50000 hrs (LED Backlight) |

TOUCH

| | |
|----------------------|---------------------|
| Resistive 5-wire | VIO-217R/MX100 only |
| Projected Capacitive | VIO-217C/MX100 only |

I/O

| | |
|-------------------|----------------------|
| VGA Input | 1x VGA Input |
| DVI-D Input | 1x DVI-D Input |
| DisplayPort Input | 1x DisplayPort Input |
| USB 2.0 Input | 1x USB 2.0 Input |
| COM Port Input | 1x COM Port Input |
| Audio Input | 1x Audio Input |

OTHER FEATURES

| | |
|------------------|--|
| Internal Speaker | AMP 10W + 10W |
| OSD | LCD On/Off, Auto, Menu, Up and Down Multi-language |

POWER

| | |
|----------------------|--|
| Power Supply Voltage | 9~48VDC |
| Power Connector | 3-pin Terminal Block |
| Power Adaptor | Optional AC/DC 12V/5A, 60W |
| Power Protection | OVP (Over Voltage Protection) OCP (Over Current Protection) Reverse Protection |

ENVIRONMENT

| | |
|---------------------------|-----------------------------------|
| Operating Temp. | -10°C to 60°C |
| Storage Temp. | -20°C to 70°C |
| Relative Humidity | 10%~80% (non-condensing) |
| IP Level | IP 65 Compliant Front Panel |
| Vibration | 1.5 Grms, 5 - 500 Hz, 0.5 hr/axis |
| Shock | 20G, half sine, 11ms |
| Standards / Certification | CE, FCC Class A |

PHYSICAL

| | |
|--------------------------|--|
| Front Panel Construction | Die-cast Flat Surface |
| Dimension | 407.5 (W) x 339 (D) x 70.5 (H) mm |
| Weight | VIO-217R/MX100: 6.38 kg VIO-217C/MX100: 6.30 kg |
| Mounting | VESA Mounting Holes 75 x 75mm, 100 x 100mm |

Rear I/O

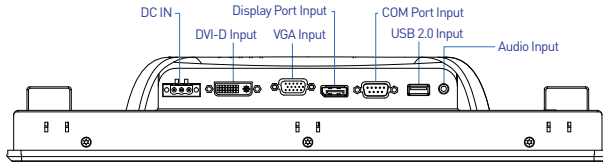

Right I/O

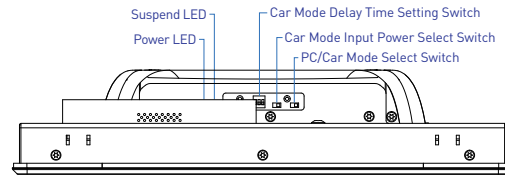

DIMENSION

Unit: mm

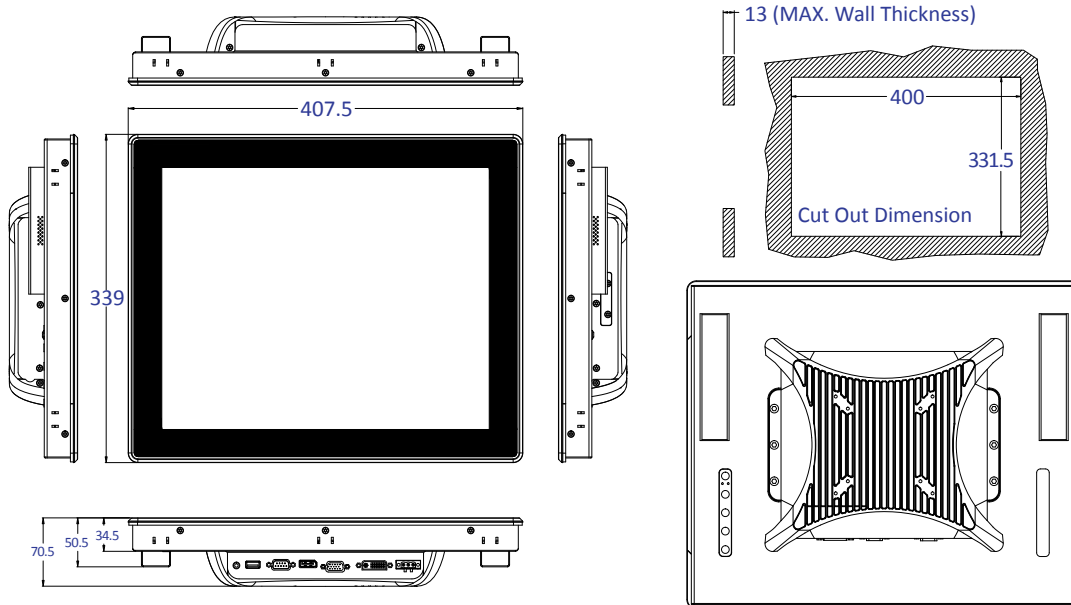

AVAILABLE MODELS

| MODEL NO. | DESCRIPTION |
|----------------|--|
| VIO-217R/MX100 | 17" SXGA Resistive Touch Thin Frame Monitor with 2x 10W Speaker |
| VIO-217C/MX100 | 17" SXGA Capacitive Touch Thin Frame Monitor with 2x 10W Speaker |

OPTIONAL ACCESSORIES

| MODEL NO. | DESCRIPTION |
|-------------|--|
| 1-E09A06002 | Adapter AC/DC 12V 5A 60W with 3pin Terminal Block Plug 5.0mm Pitch |
| SFICBL022 | Power Cord, 3-pin US Type, 180cm |
| 1-TPCD00002 | Power Cord, European Type, 180cm |
| 1-TPCD00001 | Power Cord, 3-pin UK Type, 180cm |

PACKING LIST

- 1x VIO-217/MX100 Series Touch Monitor
- 10x Panel Mount Kit
- 1x USB Cable
- 1x VGA Cable
- 1x Screw Pack