

IES7110-2GS Series

Managed Industrial Ethernet Switch

User manual

【Summarize】

IES7110-2GS series is an industrial grade, managed and redundancy Ethernet switch. It included IES7110-2GS-P (12/48VDC), IES7110-2GS-P (110/220VAC), IES7110-2GS-2F-P (12/48VDC) and IES7110-2GS-4F-P (12/48VDC). IES7110-2GS series provided some kinds of advanced network managed function, like as: SW-Ring redundancy ring network, VLAN, Trunking, Quality of Service, Speed control, port mirroring, fault alarm and firmware upgrade online. SW-Ring can bring your Ethernet to intelligent redundancy. Standard Industry design can satisfied every requirement of the industry scene. All components used industry grade, it takes products high Reliability. It provided wide voltage power supply input.

SW-Ring™ is designed as rapid redundancy network arithmetic. It provided recover technology for fault of rapid redundant network, the recovery time<20ms.

【Packing list】

The industrial Ethernet switch is shipped with the following items. If any of these items are missing or damaged, please contact your customer service representative for assistance.

- Industrial Ethernet switch × 1
- Documentation and software CD × 1
- User manual × 1
- DIN-Rail mounting kit × 1
- Warranty card × 1

【Feature】

High performance network exchange technology

- Support IEEE802.3, IEEE802.3u, IEEE 802.3x, IEEE802.3z, IEEE802.1Q, IEEE802.1p, IEEE802.1D/W
- SW-Ring ring network patent technology (Fault recovery time<20ms)
- Support RSTP, way exchange time<50ms
- Support WEB configuration
- Support MAC address learning, aging automatic

- Support port status display, data update.
- Support static and dynamic IGMP
- Support flow statistics
- Support bi-directional port mirroring
- Support rate control, Broadcast storm control
- Support configuration files up and download
- Support 1 channel relay alarm output

Reliable Industrial grade design

- Industrial grade 4 design, -40-75℃ work temperature
- No fan deign
- IP40 protection grade

【Panel layout】

Vertical view and bottom view

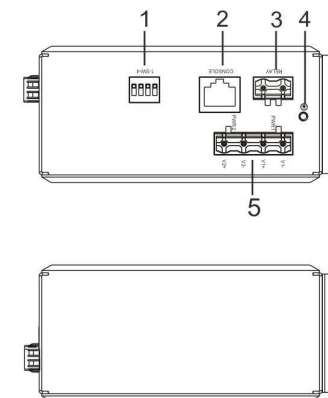

Rear view

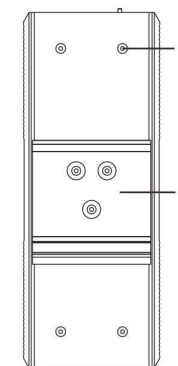

Front panel view

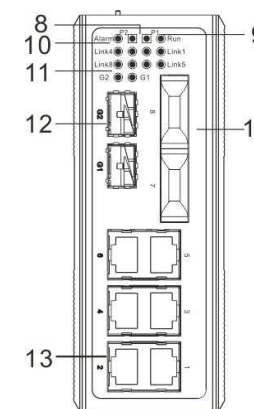
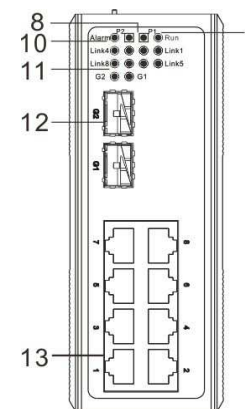

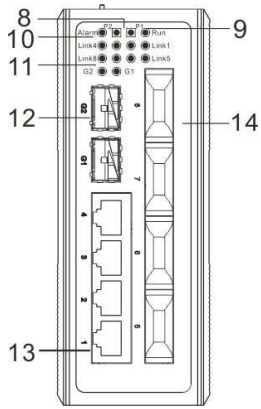

1. DIP switches for default factory
2. Console port
3. 2-pin terminal block for relay output
4. Ground screw
5. Power input terminal block
6. Screw holes for Wall Mounting Kit
7. DIN-Rail mounting kit
8. Power indicator
9. System running LED
10. Relay alarm LED
11. Link/ACT LEDs
12. Gigabit SFP port
13. 10Base-T /100Base-TX Ethernet port
14. 100Base-FX fiber port

【Power supply input】

DC Series Switch:

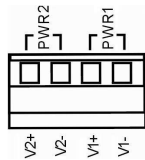

The product top panel provided 4 bit power supply input terminal block, support DC input. DC power supply input supported redundancy function, provided PWR1 and PWR2 power input,

can use for single, and can connect 2 separately power supply system, use 1 pair terminal block connect the device at the same time. If one of the power systems broke, the device can work un-interruptible. Built-in overcurrent protection, Reverse connection protection. Voltage input range is 12 ~ 48VDC (terminal block defined as: V1-, V1+, V2-, V2+).

AC Series Switch:

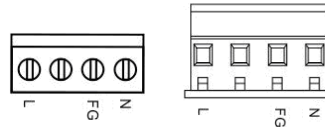

The Industrial Ethernet switches have single power and redundancy power two kinds of power input. The single power AC series top panel provides 3 bit terminal block for 100~240VAC/DC power entered (L+, FG, N/-)

Important notice:

1. Power ON operation: first of all, insert power cable's terminal block into device's power port, then insert power supply plug into power source
2. Power OFF operation: First off all, unpin power plug, then strike the terminal block, please take care of operation sequence.

【Dimension】

The series of products are the same size, and the number of the Ethernet interface is different. Unit (mm)

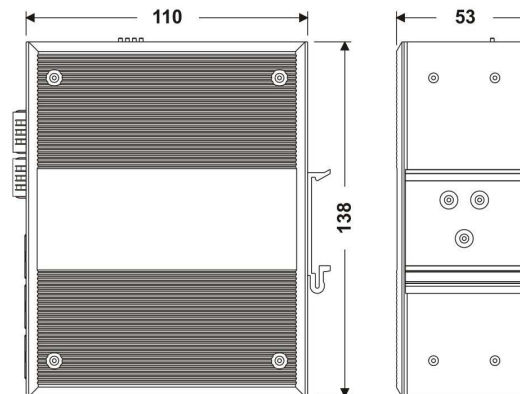

【DIP Switch】



Top panel provided 4 bits DIP switch to do function configure (ON to enable effective), 1 and 4 keep for future function. 2 is recovery default factory. 3 is for upgrade. Please power off and power on when you change the status of DIP switch.

【Relay connection】

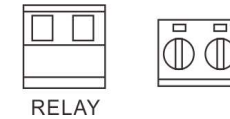

Relay access terminals in the top panel of the device. Between the two terminal relay, as an open circuit state in normal non alarm state, when there is any alarm information to the closed state. The two terminal block connector are used to detect both power failure and port failure. The two wires attached to the Fault contacts form an open circuit when the device has lost power supply from one of the DC power inputs or one of the ports is failure. (Note: The AC power switch does not support power alarm.)

【Console port】

This series product provided 1pcs procedure test port based in serial port. It adopts RJ45 interface, located in top panel, can configure related command through RJ45 to DB9 female cable.

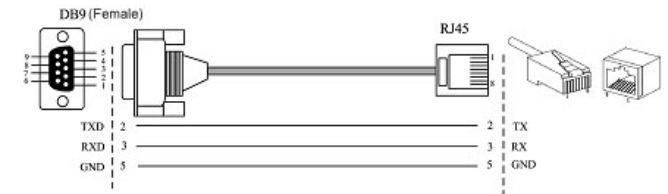

【Communication connector】

10/100BaseT(X) Ethernet port

The pinout define of RJ45 port display as below, connect by UTP or STP. The connect distance is no more than 100m. 100Mbps is

used 120 Ω of UTP 5, 10Mbps is used 120 Ω of UTP 3 ,4, 5.

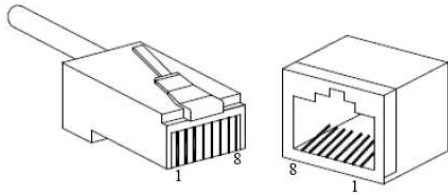

RJ45 port support automatic MDI/MDI-X operation. can connect the PC, Server, Converter and HUB .Pin 1,2,3,6 Corresponding connection in MDI. 1→3, 2→6, 3→1, 6→2 are used as cross wiring in the MDI-X port of Converter and HUB. 10Base-T/100Base-TX are used in MDI/MDI-X, the define of Pin in the table as below.

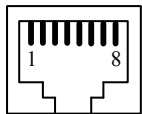

NO.	MDI signal	MDI-X signal
1	TX+	RX+
2	TX-	RX-
3	RX+	TX+
6	RX-	TX-
4, 5, 7, 8	—	—

Note: “TX±” Transmit Data±, “RX±” Receive Data±, “—” Not use.

10/100Base-T(X) MDI (straight-through cable)

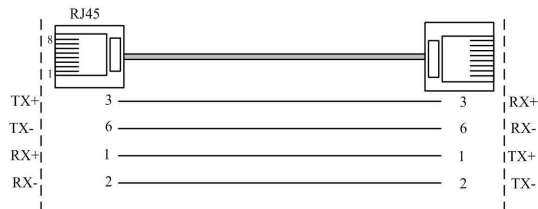

10/100Base-T(X) MDI-X (Cross over cable)

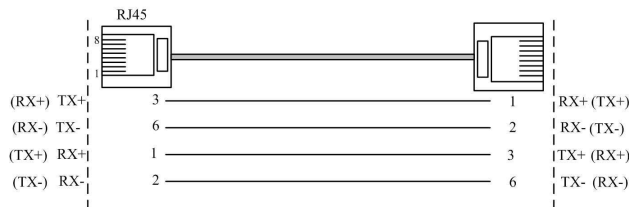

MDI/MDI-X auto connection makes switch easy to use for customers without considering the type of network cable.

100Base-FX Fiber port

100Base-FX full-duplex SM or MM port, SC/ST/FC type .The fiber port must be used in pair, TX (transmit) port connect remote switch’s RX(receive) port; RX(receive) port connect remote switch’s TX(transmit) port.

The optical fiber connection supports the line to instruct enhance the reliability of network effectively.

Suppose: If you make your own cable, we suggest labeling the two sides of the same line with the same letter (A-to-A and B-to-B, shown as below, or A1-to-A2 and B1-to-B2).

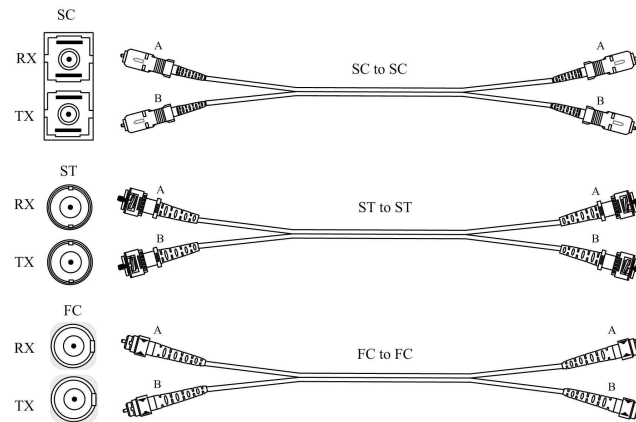

1000Base SFP fiber port(mini-GBIC)

1000Base- SFP fiber port adopts gigabit mini-GBIC transmission, can choice different SFP module according to different transfer distance. Fiber interface must use for pair, TX port is transmit side, must connect to RX (receive side). The fiber interface support loss line indicator.

Suppose: If you make your own cable, we suggest labeling the two sides of the same line with the same letter (A-to-A and B-to-B, shown as below, or A1-to-A2 and B1-to-B2).

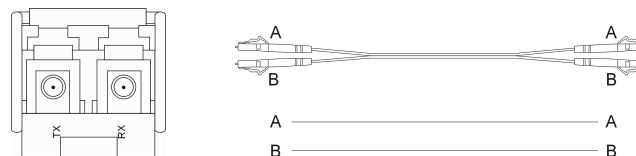

【LED Indicator】

LED indicator light on the front panel of product, the function of each LED is described in the table as below.

System indication LED		
LED	State	Description
P1	ON	Power is being supplied to power input PWR1
	OFF	Power is not being supplied to power input PWR1
P2	ON	Power is being supplied to power input PWR2
	OFF	Power is not being supplied to power input PWR2
Alarm	ON	When the alarm is enabled, power or the port’s link is inactive.
	OFF	Power and the port’s link is active, the alarm is disabled.
Run	ON/OFF	System is not running well
	Blinking	System is running well
Link/ACT (1~8/G1~G2)	ON	Port connection is active
	Blinking	Data transmitted
	OFF	Port connection is not active

【Installation】

Before installation, confirm that the work environment meet the installation require, including the power needs and abundant space. Whether it is close to the connection equipment and other equipments are prepared or not.

1. Avoid in the sunshine, keep away from the heat fountainhead or the area where in intense EMI.
2. Examine the cables and plugs that installation requirements.
3. Examine whether the cables be seemly or not (less than 100m) according to reasonable scheme.

- Power: DC dual power supply series products 12~48VDC
AC single power supply series products 100~240VAC/DC

- Environment: working temperature: -40~75°C
Storage Temperature: -40~85°C
Relative humidity 5%~95%

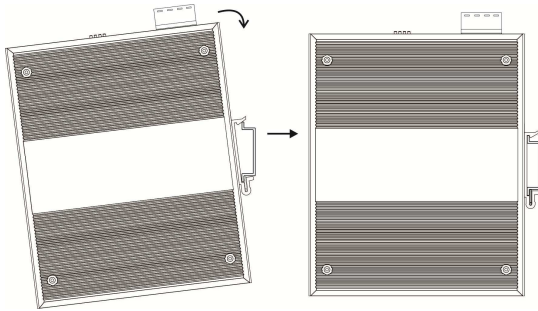

DIN Rail Installation

In order to use in industrial environments expediently, the product adopt 35mm DIN-Rail installation, the installation steps as below:

- Examine the DIN-Rail attachment
- Examine DIN Rail whether be firm and the position is suitability or not.
- Insert the top of the DIN-Rail into the slot just below the stiff metal spring.
- The DIN-Rail attachment unit will snap into place as shown below.

Wiring Requirements

Cable laying need to meet the following requirements,

- It is needed to check whether the type, quantity and specification of cable match the requirement before cable laying;
- It is needed to check the cable is damaged or not, factory records and quality assurance booklet before cable laying;
- The required cable specification, quantity, direction and laying position need to match construction requirements, and cable length depends on actual position;

- All the cable cannot have break-down and terminal in the middle;
- Cables should be straight in the hallways and turning;
- Cable should be straight in the groove, and cannot beyond the groove in case of holding back the inlet and outlet holes. Cables should be banded and fixed when they are out of the groove;
- User cable should be separated from the power lines. Cables, power lines and grounding lines cannot be overlapped and mixed when they are in the same groove road. When cable is too long, it cannot hold down other cable, but structure in the middle of alignment rack;
- Pigtail cannot be tied and swerved as less as possible. Swerving radius cannot be too small (small swerving causes terrible loss of link). Its banding should be moderate, not too tight, and should be separated from other cables;
- It should have corresponding simple signal at both sides of the cable for maintaining.

【Specification】

Technology

Standard: Support IEEE802.3, IEEE802.3u, IEEE802.3x, IEEE802.3z, IEEE802.1Q, IEEE802.1p, IEEE802.1D/W
Protocol: ARP, ICMP, TCP, UDP, DHCP, DNS, HTTP, Telnet, SW-Ring, RSTP, SNMP

Flow control: IEEE802.3x flow control, back press flow control

Interface

Electric port: 10Base-T/100Base-TX/1000Base-TX auto speed control, Half/full duplex and MDI/MDI-X auto detect

100M optic fiber port: 100Base-FX, SC/ST/FC connector

Gigabit SFP port: 1000Base-FX, SFP slot

Console port: debug serial port carry out CLI command

Alarm port: 2 bit 7.62mm terminal block,
1 channel relay alarm output

Exchange attribute

100M forward speed: 148810pps

1000M forward speed: 1488100pps

Transmit mode: store and forward

System exchange bandwidth: 7.6G

MAC address table: 8K

Memory: 1M

Transfer distance

Twisted cable: 100M (standard CAT5/CAT5e cable)

Multi-mode: 1310nm, 2Km

Single-mode: 1310nm, 20/40/60Km

1550nm, 80/100/120Km

Power supply

✧ DC input series

Input voltage: 12~48VDC

✧ AC input series

Input voltage: 100~240VAC/DC

Type of input: 4 bit 7.62mm pitch terminal block

Overload current protect: 4.0A (DC) or 5.0A (AC)

Support DC dual power supply redundancy and alarm input

Support DC input no parity, protection reverse connection

Consumption

➤ IES7110-2GS-P (12/48VDC):

Unload consumption: 2.2W@24VDC

Full load consumption: 5.5W@24VDC

➤ IES7110-2GS-P (220VAC):

Unload consumption: 2.7W@220VAC

Full load consumption: 5.5W@220VAC

➤ IES7110-2GS-2F-P (12/48VDC):

Unload consumption: 5.1W@24VDC

Full load consumption: 8.0W@24VDC

➤ IES7110-2GS-4F-P (12/48VDC):

Unload consumption: 6.1W@24VDC

Full load consumption: 9.0W@24VDC

Working environment

Working temperature: -40~75℃

Storage temperature: -40~85℃

Relative Humidity: 5%~95% (no condensation)

Mechanical Structure

Shell: IP40 protect grade, metal shell

Installation: DIN-Rail mounting

Weight: 720g

Size (W×H×D) : 110mm×138mm×53mm

Industry Standard

EMI: FCC Part 15, CISPR (EN55022) class A

EMS: EN61000-4-2 (ESD), Level 4

EN61000-4-3 (RS), Level 3

EN61000-4-4 (EFT), Level 4

EN61000-4-5 (Surge), Level 4

EN61000-4-6 (CS), Level 3

EN61000-4-8, Level 5

Shock: IEC 60068-2-27

Free fall: IEC 60068-2-32

Vibration: IEC 60068-2-6

Certification

CE, FCC, RoHS, UL508 (Pending)

Warranty: 5 years