

BASRT-B

BACnet/IP to MS/TP Router

Installation Guide

TD071200-01D

For Firmware Versions 1.x

CONTEMPORARY CONTROLS®

Trademarks

Contemporary Controls, ARC Control, ARC DETECT, EXTEND-A-BUS, RapidRing, and CTRLink are trademarks or registered trademarks of Contemporary Control Systems, Inc. Specifications are subject to change without notice. Other product names may be trademarks or registered trademarks of their respective companies. BACnet is a registered trademark of the American Society of Heating, Refrigeration, and Air-Conditioning Engineers, Inc. (ASHRAE).

TD071200-0ID 16 September 2009

Copyright

© Copyright 2009 by Contemporary Control Systems, Inc. All rights reserved. No part of this publication may be reproduced, transmitted, transcribed, stored in a retrieval system, or translated into any language or computer language, in any form or by any means, electronic, mechanical, magnetic, optical, chemical, manual, or otherwise, without the prior written permission of:

Contemporary Control Systems, Inc.

2431 Curtiss Street
Downers Grove, Illinois 60515 USA
Tel: 1-630-963-7070
Fax: 1-630-963-0109
E-mail: info@ccontrols.com
Web: www.ccontrols.com

Contemporary Controls Ltd

Sovereign Court Two, UWSP
Sir William Lyons Road
Coventry, CV4 7EZ, UK
Tel: +44 (0)24 7641 3786
Fax: +44 (0)24 7641 3923
E-mail: info@ccontrols.co.uk
Web: www.ccontrols.co.uk

Contemporary Controls (Suzhou) Co. Ltd

11 Huoju Road, Science & Technology Park
New District, Suzhou, PR China 215009
Tel: +86-512-68095866
Fax: +86-512-68093760
E-mail: info@ccontrols.com.cn
Web: www.ccontrols.com.cn

Contemporary Controls GmbH

Fuggerstraße 1 B
04158 Leipzig, Germany
Tel: +49 0341 520359 0
Fax: +49 0341 520359 16
E-mail: info@ccontrols.de
Web: www.ccontrols.de

Disclaimer

Contemporary Control Systems, Inc. reserves the right to make changes in the specifications of the product described within this manual at any time without notice and without obligation of Contemporary Control Systems, Inc. to notify any person of such revision or change.

TD071200-0ID

Contents

1	Introduction	4
2	Specifications.....	5
	Electrical.....	5
	Environmental.....	5
	Mounting	5
	Functional.....	5
	Electromagnetic Compatibility	5
	Connectors.....	6
	EIA-485 Bias and Termination Jumpers	6
	Mechanical	6
3	Power.....	7
	POWER SUPPLY PRECAUTIONS	7
	Limited Power Sources	10
4	LEDS.....	10
5	Operation	11
	MS/TP Port.....	11
	Ethernet Port	12
	IP Address Reset Switch	12
6	Webpage Configuration	13
	Device Parameter	16
	BACnet/IP Parameters	16
	MS/TP Parameters	17
7	Warranty.....	19
8	Declaration of Conformity.....	20

1 Introduction

The BASRT-B routes messages between BACnet/IP and BACnet MS/TP networks as per the ANSI/ASHRAE 135-2004 standard. It allows BACnet/IP devices operating over Ethernet to communicate with MS/TP devices. The router is configurable via its internal webpage.

The BASRT-B comes in a metal case, is DIN-rail mounted and is powered from a 24 VAC/VDC source. It has one isolated MS/TP port and one 10/100 Mbps Ethernet Auto-MDIX port.

The MS/TP port offers a 3-pin terminal block with a removable plug for the EIA-485 connection. Through this port, up to 254 devices can be addressed — as many as 31 full-load devices on the attached segment. All MS/TP baud rates (as stated in the BACnet standard) are supported.

The Ethernet port offers a shielded RJ-45 connector. Through auto-negotiation and Auto-MDIX, it automatically matches its duplex setting, data rate and communication pair usage to whatever is needed by the attached equipment. Thus, only a straight-through CAT5 cable is needed for hook-up.

The BASRT-B features a user-accessible switch to reset the IP address, subnet mask and gateway address to the factory defaults.

Three LEDs are present: A power LED glows green when proper power is provided. The Ethernet LED glows green for 100 Mbps operation and yellow for 10 Mbps and flashes to indicate activity. A green LED flashes when MS/TP traffic is received.

Each unit complies with Class A radiated and conducted emissions as defined by EN55022 and CFR 47, Part 15, and is intended for use in non-residential areas.

When using the BASRT-B to communicate on routed IP networks (ones which use multiple IP subnets), a separate device with BBMD functionality must be provided. If all IP devices use the same subnet, then BBMD functionality is not required. For example, if the BASRT-B uses IP address 192.168.1.1 and another BACnet/IP device (which will communicate with the BASRT-B) uses 10.0.0.1, then BBMD functionality is required from another device on your network.

2 Specifications

Electrical

INPUT	DC	AC
Voltage ($\pm 10\%$):	24 V	24 V
Current (maximum):	125 mA	125 mA
Power:	3 W	3 VA
Frequency:	N/A	47–63 Hz

(Class 2 Circuits Only)

Environmental

Operating temperature:	0°C to 60°C
Storage temperature:	-40°C to +85°C
Relative humidity:	10–95%, non-condensing

Mounting

TS-35 DIN-rail

Functional

	Ethernet	<i>MS/TP</i>
Physical Layer:	10BASE-T 100BASE-TX	<i>EIA-485</i>
Cable length limit:	100 m	<i>1200 m (for AWG 18)</i>
MS/TP Baud rate (bps):	9600, 19200, 38400, 76800	
MS/TP node limit:	254 devices total, 31 full-load devices per segment	
MS/TP LED:	flashing green = receive valid activity	
Ethernet LED:	green = 100 Mbps yellow = 10 Mbps flashing = activity	

Regulatory Compliance

CE Mark; RoHS; CFR47, Part 15 Class A

Electromagnetic Compatibility

Each unit complies with Class A radiated and conducted emissions as defined by EN55022 and CFR 47, Part 15. This equipment is intended for use in non-residential areas.

Warning This is a Class A product as defined in EN55022. In a domestic environment this product may cause radio interference in which case the user may be required to take adequate measures.

TD071200-0ID

Connectors

3-pin (MS/TP) Pin Assignments

(Also explained on product label)



Figure 1 — 3-pin Connector

RJ-45 (MDI Ethernet) Pin Assignments

- | | | | |
|---|------|---|------|
| 1 | TD + | 3 | RD + |
| 2 | TD - | 6 | RD - |

(All other pins are unused.)

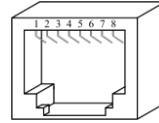

Figure 2 — RJ-45 Connector

USB Mini B Connector (Aux)

This connector is only used for firmware upgrades.

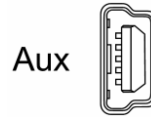

Figure 3 — USB Connector

EIA-485 Bias and Termination Jumpers

- U Install jumper to apply pull-up bias.
- T Install jumper to terminate bus.
- D Install jumper to apply pull-down bias.



(All jumpers are installed by default.)

Figure 4 — Internal Jumpers

Mechanical

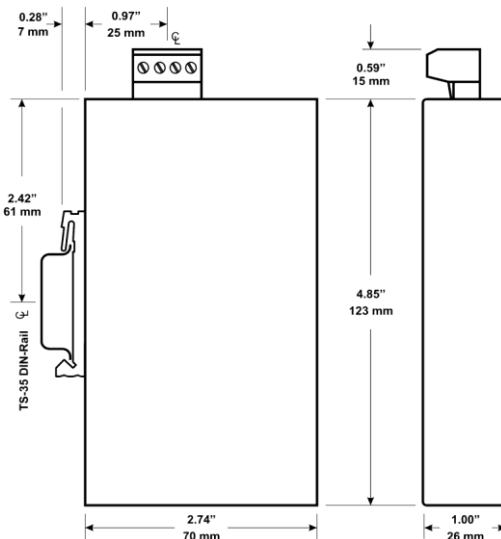

Figure 5 — Product Dimensions

TD071200-0ID

3 Power

The BASRT-B requires 24 VAC or 24 VDC (see *Figure 6*) while drawing no more than 3 W of power. The recommended conductor size is 16–18 AWG. COM is directly connected to zero volts and the chassis is DC isolated from zero volts. Input connections are reverse-polarity protected.

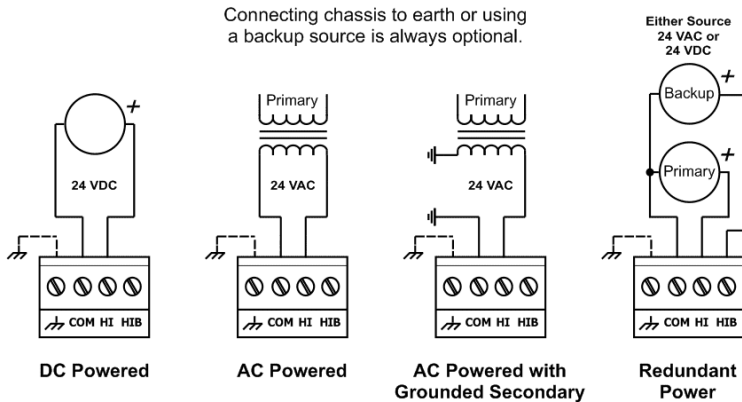

Figure 6 — Power Options

WARNING: Powering devices can present hazards. Read the text on the following page carefully.

POWER SUPPLY PRECAUTIONS

Internally, the router utilizes a half-wave rectifier and therefore can share the same AC power source with other half-wave rectified devices. Sharing a common DC power source is also possible. Sharing AC power with full-wave rectified devices is NOT recommended. Full-wave rectified devices usually require a dedicated AC power source that has a secondary elevated above ground. Both secondary connections are considered HOT.

AC power sources that power several half-wave devices have a common secondary connection called either COMMON, LO, or GROUND. This connection might be tied to frame ground or earth. The other side of the secondary is considered the HOT or HI side of the connection. Connect the HOT side of the secondary to either the HI or the HIB input on the router and the LO side to COM on the router. All other half-wave devices sharing the same AC power source need to follow the same convention. When using a DC power source, connect the positive terminal of the source to either the HI or the HIB input and the negative terminal to COM on the router. Reversing polarity to the router will not damage the router. If shielded cable is used, it is recommended to tie all shield segments together and connect one of the shield ends to chassis while taping back the other.

For MS/TP devices that share a power source with the BASRT-B, see Figure 7 for proper 2-wire bus connections and Figure 8 for proper 3-wire bus connections.

WARNING: Devices powered from a common AC source could be damaged if a mix of half-wave and full-wave rectified devices exist. If you are not sure of the type of rectifier used by another device, do not share the AC source with it.

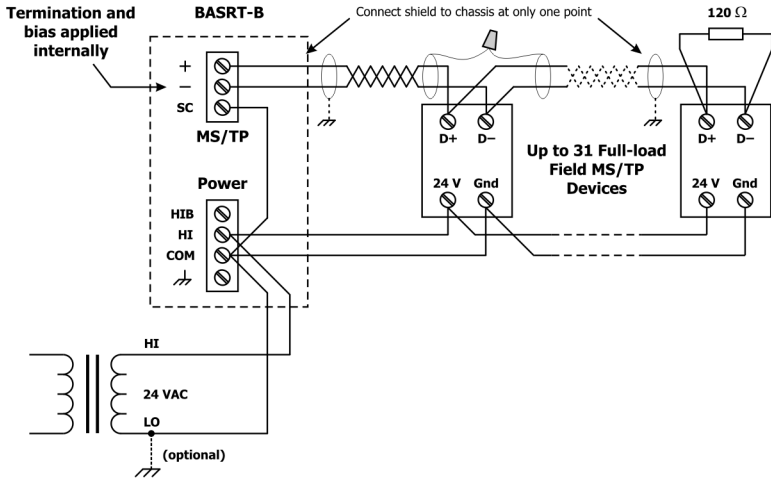

Figure 7 — 2-wire MS/TP Bus with Shared Power Source

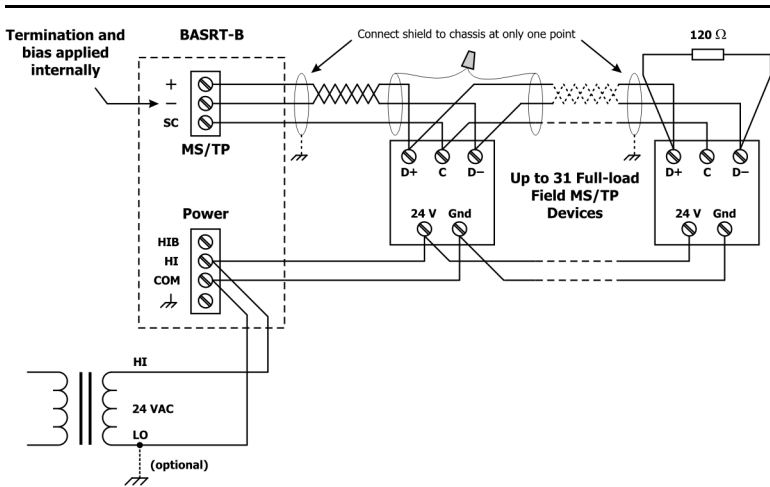

Figure 8 — 3-wire MS/TP Bus with Shared Power Source

For MS/TP devices that use a power source separate from the BASRT-B, see Figure 9 for proper 2-wire bus connections and Figure 10 for proper 3-wire bus connections.

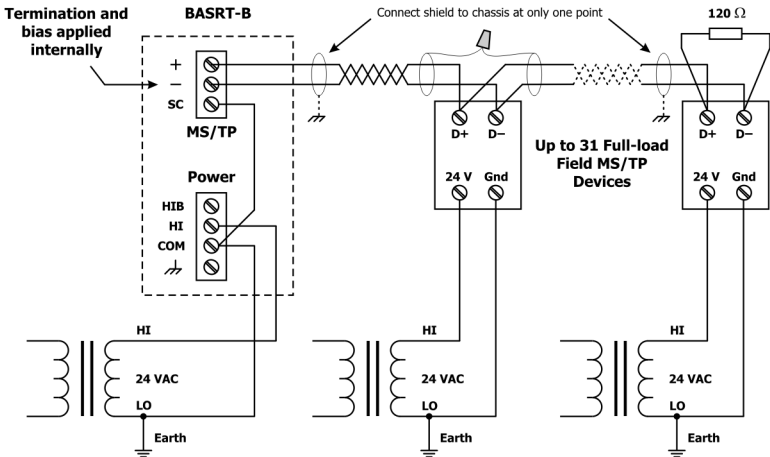

Figure 9 — 2-wire MS/TP Bus with Separate Power Sources

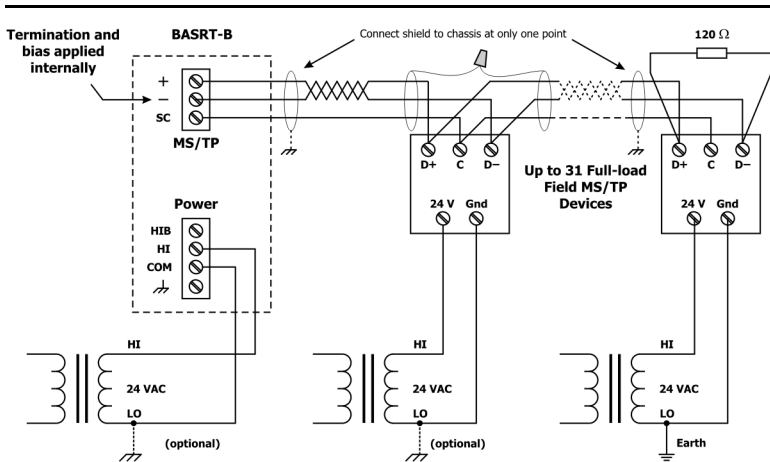

Figure 10 — 3-wire MS/TP Bus with Separate Power Sources

Limited Power Sources

The router should be powered by a limited power source complying with the requirements of the National Electric Code (NEC) article 725 or other international codes meeting the same intent of limiting the amount of power of the source. Under NEC article 725, a Class 2 circuit is that portion of the wiring system between the load side of a Class 2 power source and the connected equipment. For AC or DC voltages up to 30 volts, the power rating of a Class 2 power source is limited to 100 VA. The transformer or power supply complying with the Class 2 rating must carry a corresponding listing from a regulatory agency such as Underwriters Laboratories (UL).

4 LEDs

- Power* glows green if power supplied to the unit is proper
- Ethernet* glows solid for a valid link (green for 100 Mbps or yellow for 10 Mbps) and flashes to show activity
- MS/TP* flashes green when receiving valid MS/TP traffic

5 Operation

MS/TP Port

The MS/TP port uses an isolated EIA-485 transceiver that is connected to a 3-pin removable connector (*Figure 1*). The EIA-485 transceiver's + and - lines tie to + and - pins of the connector. The SC pin ties to the circuit ground of the EIA-485 transceiver.

In *Figure 11* a simplified schematic of the isolated EIA-485 transceiver is shown. Notice that the transceiver common (SC) is electrically isolated from the router power supply common (COM) through the use of opto-isolators and an isolated DC-DC converter. By providing an isolated EIA-485 transceiver there is less opportunity to damage the transceiver by subjecting it to high common-mode voltages, but there is still a risk. Surge suppression is applied between the two differential inputs and between each input and ground. Since the transceiver is electrically isolated, the transceiver's circuit common must be brought out for connection to the other devices on the MS/TP network. This is accomplished by pin SC. The differential pair is labelled + and - and corresponds to the same designations in the BACnet MS/TP standard. This requires a three-wire connection to the MS/TP network. When connecting other isolated MS/TP devices there is no problem since each device requires a 3-wire connection. Just make corresponding connections. For non-isolated MS/TP devices, usually only a 2-wire connection is provided. The third wire is the power supply common. In this situation, the SC connection must be made to the power supply common of the non-isolated device. Refer to the device vendor's instructions for connecting such a device.

In a router application where one connection is made to Ethernet and the other to MS/TP, the location of the router is probably at the end of the MS/TP bus segment and therefore both bias and termination must be applied to the segment end. The router is shipped with bias and termination applied, but this can be changed by removing three jumpers. This should be done if the router is to be connected anywhere between the end MS/TP devices.

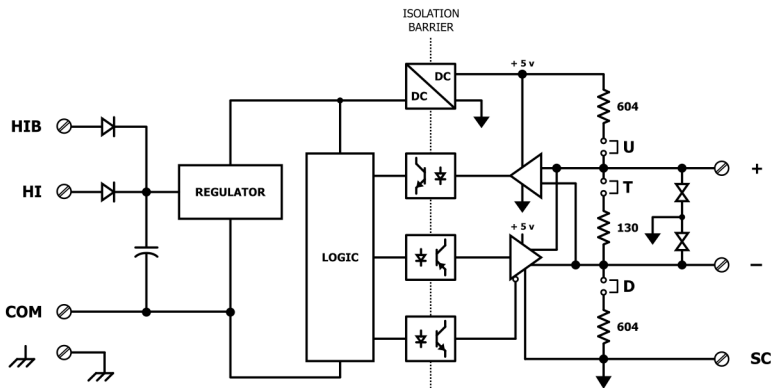

Figure 11 — Isolated EIA-485 Transceiver Circuitry

The router can address 254 MS/TP devices and supports 31 devices on the local bus at rates of 9600, 19200, 38400, or 76800 bps.

EIA-485 Bias and Termination Jumpers

After removing the BASRT-B cover, three jumpers are accessible on a 6-pin jumper block located near the MS/TP connector. These impart 604 ohms of pull-up and pull-down bias at jumpers U and D, and 130 ohms of termination impedance for the T jumper. With all three jumpers installed, the effective termination resistance is 120 Ω — consistent with the BACnet standard. If the BASRT-B is not installed at the end of a segment, remove all the jumpers and install 120 Ω at the far end of the bus.

Ethernet Port

This port offers a shielded RJ-45 connector. Through auto-negotiation and Auto-MDIX, it automatically matches its duplex setting, data rate and communication pair usage to whatever is needed by the attached equipment. Thus, any CAT5 cable (cross-over or straight-through) may be used to connect to the Ethernet.

IP Address Reset Switch

To reset the router to it's default values of the IP address (192.168.92.68), gateway address (192.168.92.1) and netmask (/24 or 255.255.255.0), use a paperclip or similar tool to press the reset button for at least 3 seconds while the router is powered. Release the reset button. Then remove power from the router for 3 seconds. Restore power and the unit will now use the default values.

6 Webpage Configuration

Each router contains an interactive web server, accessible from any Internet-compatible PC on the local network and compatible with recent versions of Internet Explorer (5.0 or later, suggested) or Netscape Navigator (7.1 or later, required). It is factory-programmed with a default IP address of 192.168.92.68 and a Class C subnet mask of 255.255.255.0 (/24).

Figure 12 shows the setup for accessing the MS/TP network using BASRT-B, a computer for configuration, and a connection to the MS/TP network.

To configure the router, attach it to a computer with an Ethernet connection and a standard web browser. For initial configuration, the PC chosen for the procedure should temporarily have its IP address modified as illustrated in *Figure 13* — which employs a Windows[®] XP example.

The example in *Figure 13* suggests an IP address for the PC of 192.168.92.**69**, but the final quad of the address could be any value from 3 to 254 — except for **68** which is used by the router. After the IP address of the PC has been set to the same subnet as the router, a browser can access the router via its default IP address.

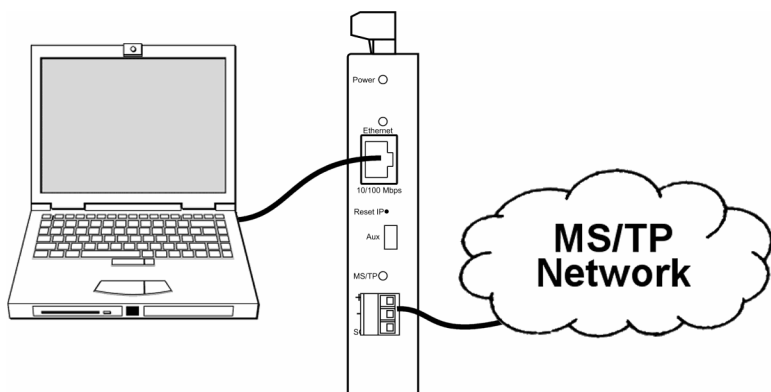

Figure 12 — Setup for Initial IP Address Configuration

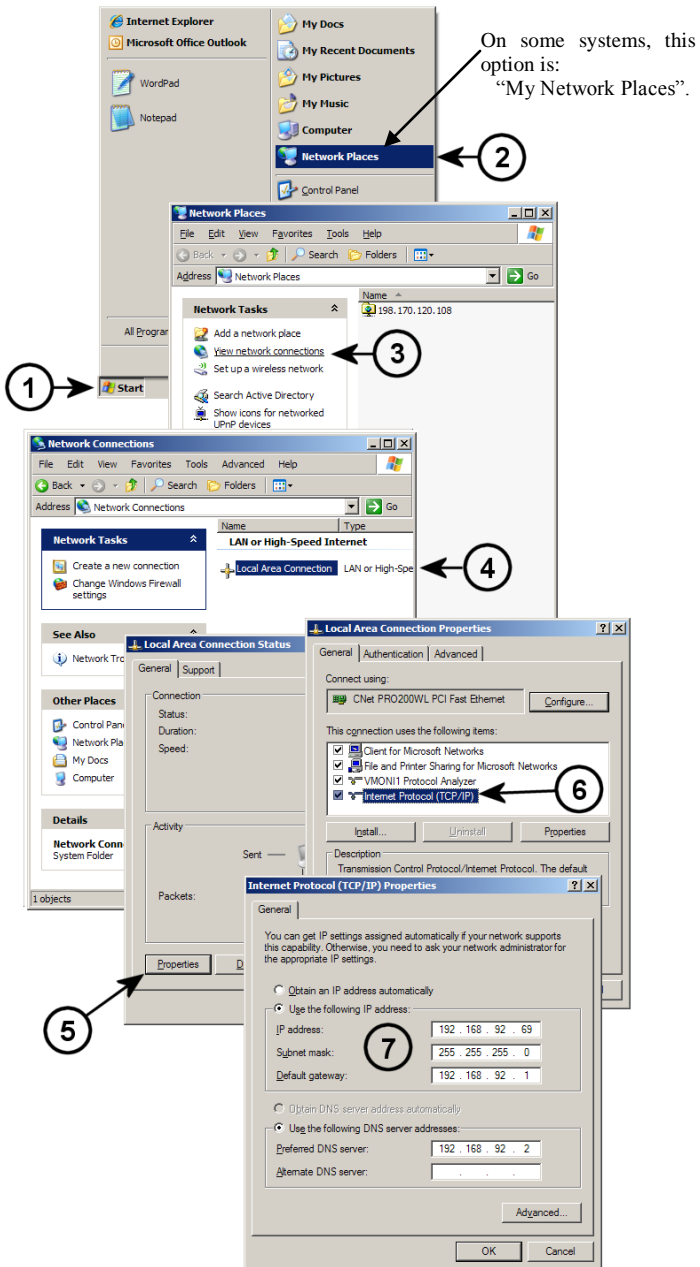

Figure 13 — Steps for Changing the IP Address of the PC Used for Setup

TD071200-01D

After entering the router's IP address into your browser's address field, you will see the Router Configuration Page with the default values as shown in *Figure 14* — using Windows Internet Explorer.



Figure 14 — Router Configuration Page with Default Values

Each configuration parameter is explained on the following pages. When *save changes* is selected, the parameters are stored to non-volatile memory and you are prompted to recycle power to the unit. Until power is removed and then restored, your changes **will not apply**.

Device Parameter

Device Instance (Default Value = 0)

The router's device instance is a 22-bit value (0–4,194,302). Do not use 4,194,303 which is reserved by BACnet. Each BACnet device within the same BACnet internetwork must have a unique device instance. One must be assigned to the BASRT-B.

BACnet/IP Parameters

BACnet/IP UDP Port (Default Value = 0xBAC0)

This 16-bit hex value (BAC0–BACF) is set to BAC0 by default. Usually, this default value should not be changed. In a typical installation, each BASRT-B will be assigned the same UDP port.

BACnet/IP Network (Default Value = 1)

The BACnet/IP network number is a 16-bit value (1–65534). Each network within the BACnet internetwork must have a unique number. This includes the BACnet/IP and MS/TP sides of the BASRT-B. Do not use addresses 0 or 65535 since these addresses are reserved.

IP Address (Default Value = 192.168.92.68)

The IP address of the router can be 0.0.0.1–255.255.255.254. A private address is usually assigned to the BASRT-B.

IP Subnet (Default Value = 24)

This value (0–30 in the “slash” notation) is the number of *bits* with a “1” in the mask. The default value of 24 corresponds to 255.255.255.0 in the dotted *decimal* format. All devices on the same subnet which communicate via BACnet/IP should use the same subnet mask.

IP Gateway (Default Value = 192.168.92.1)

The default gateway for the IP stack is a dotted decimal number in the range of 0.0.0.0–255.255.255.254. This will be the IP address of your local IP router — if one exists.

MS/TP Parameters

MS/TP MAC (Default Value = 00)

This is the unique 8-bit (0–127) MAC address of the router's MS/TP port, in decimal. Lower MAC address numbers are preferred with the default recommended. It is further recommended that all other BACnet devices attached to the same MS/TP network be assigned consecutive MAC addresses beginning with 1 without allowing any gaps in addressing. Slave devices may have MAC addresses of 128–254, but MAC address 255 is reserved.

MS/TP Network (Default Value = 2001)

This 16-bit decimal network number (1–65534) must be unique for all BACnet networks within the BACnet internetwork. No other networks, regardless of type, can have the same network number. Do not use addresses 0 or 65535 since these addresses are reserved.

Max Masters (Default Value = 127)

Only master nodes participate in the MS/TP token-passing process. The highest master MAC address (in decimal) in the MS/TP network is 127 and you should use 127 if you are unsure of other MS/TP device addresses. Each MS/TP device should use this same value. For a value in this field to be proper, it must equal or exceed the highest MAC address for any master on the network. Optimum performance occurs when this value:

1. *equals* the highest MAC address of any master, and
2. all masters use *sequential* MAC addresses starting with 1

Since many BACnet devices do not allow this parameter to be changed, leave the BASRT-B at the default value.

Max Info Frames (Default Value = 100)

This is the maximum number of messages that can be routed onto the MS/TP network by the router per token pass. Its range is 1–100, and typical values are 20–40. Smaller values provide less access to the MS/TP network from the BACnet/IP network because they give native MS/TP messages higher priority than

those passed by the router from BACnet/IP. The default value usually provides good performance.

MS/TP Baud Rate (Default Value = 38400)

The baud rate of the MS/TP network can be 9600, 19200, 38400 or 76800 bps. All MS/TP devices on the same MS/TP network must use the same baud rate. On power up the router checks for other masters; if finding none, it begins token passing — at which point autobauding devices will adjust to the router's baud rate.

MS/TP Tolerance (Default Selection = Strict)

This setting determines the degree to which interoperability with devices is successful. The Lenient option is less efficient for traffic flow but optimizes interoperability. A slight improvement in performance will be realised by selecting the *Strict* setting.

7 Warranty

Contemporary Controls (CC) warrants this product to the original purchaser for two years from the product shipping date. Product returned to CC for repair is warranted for one year from the date the repaired product is shipped back to the purchaser or for the remainder of the original warranty period, whichever is longer.

If the product fails to operate in compliance with its specification during the warranty period, CC will, at its option, repair or replace the product at no charge. The customer is, however, responsible for shipping the product; CC assumes no responsibility for the product until it is received.

CC's limited warranty covers products only as delivered and does not cover repair of products that have been damaged by abuse, accident, disaster, misuse, or incorrect installation. User modification may void the warranty if the product is damaged by the modification, in which case this warranty does not cover repair or replacement.

This warranty in no way warrants suitability of the product for any specific application. IN NO EVENT WILL CC BE LIABLE FOR ANY DAMAGES INCLUDING LOST PROFITS, LOST SAVINGS, OR OTHER INCIDENTAL OR CONSEQUENTIAL DAMAGES ARISING OUT OF THE USE OR INABILITY TO USE THE PRODUCT EVEN IF CC HAS BEEN ADVISED OF THE POSSIBILITY OF SUCH DAMAGES, OR FOR ANY CLAIM BY ANY PARTY OTHER THAN THE PURCHASER.

THE ABOVE WARRANTY IS IN LIEU OF ANY AND ALL OTHER WARRANTIES, EXPRESSED OR IMPLIED OR STATUTORY, INCLUDING THE WARRANTIES OF MERCHANTABILITY, FITNESS FOR PARTICULAR PURPOSE OR USE, TITLE AND NONINFRINGEMENT.

Returning Products for Repair

Before returning a product for repair, contact Customer Service. A representative will instruct you about our return procedure.

Contemporary Control Systems, Inc.
2431 Curtiss Street
Downers Grove, Illinois 60515 USA
Tel: +1-630-963-7070
Fax: +1-630-963-0109
E-mail: info@ccontrols.com
WWW: <http://www.ccontrols.com>

Contemporary Controls Ltd
Sovereign Court Two, UWSP
Sir William Lyons Road
Coventry CV4 7EZ UK
Tel: +44 (0)24 7641 3786
Fax: +44 (0)24 7641 3923
E-mail: info@ccontrols.co.uk

TD071200-0ID

8 Declaration of Conformity

Applied Council Directives:

Low Voltage Directive 2006/95/EC

General Product Safety Directive 2001/95/EC

Electromagnetic Compatibility Directive 2004/108/EC

Restriction of Hazardous Substances Directive 2002/95/EC

Waste Electrical and Electronic Equipment Directive 2002/96/EC

Standards to which Conformity is Declared

EN 55022:1998 + A1:2000 + A2:2003, Class A, Limits and Methods of Measurement of Radio Disturbance Characteristics of Information Technology Equipment

EN 55024:1998 + A1:2001 + A2:2003, Information Technology Equipment — Immunity Characteristics — Limits and Methods of Measurement

Manufacturer:

Contemporary Control Systems, Inc.
2431 Curtiss Street
Downers Grove, IL 60515 USA

Authorized Representative:

Contemporary Controls Ltd
Sovereign Court Two, UWSP
Sir William Lyons Road
Coventry CV4 7EZ UK

Type of Equipment:

BACnet/IP to MS/TP router

Model:

BASRT-B

I, the undersigned, hereby declare that the products specified above conform to the listed directives and standards.

George M. Thomas, President

September 2009